

## Multilayer Varistor ESD Suppressor MLVA Series



### Description

Cooper Bussmann® MLVA Series of multilayer varistors are designed to protect electronic circuits from ESD damage. With its small, standardized 0201, 0402 and 0603 sizes, it's easy to implement them into any circuit board design. The MLVA is suitable for push button, power line and low frequency overvoltage protection.

### Features

- Zinc oxide based ceramic chip
- Provides ESD protection with fast response time (<1ns) allowing equipment to pass IEC 61000-4-2 Level 4 Test
- 0402 and 0603 meet IEC 61000-4-4 and 61000-4-5
- Low profile designs for board space savings
- Low and stable leakage current reduces power consumption
- Low clamping voltage
- Wide 5.5 to 26Vdc operating voltage range
- Halogen free and RoHS compliant for global applications

### Applications

- Computers and peripherals
- Digital still cameras
- Cell phones
- Medical equipment
- Printers/copiers/scanners
- DVD Players
- MP3/Multimedia players
- LCD TV / Monitor
- External storage
- Cable/DSL Modems
- Set top boxes

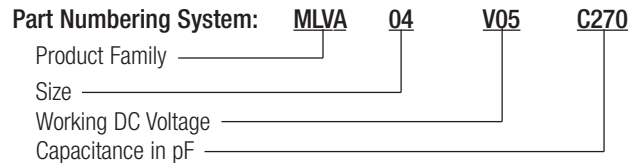

### Packaging

- Size 0201: 15,000 pieces per reel - EIA (EIAJ)
- Size 0402: 10,000 pieces per reel - EIA (EIAJ)
- Size 0603: 4000 pieces per reel - EIA (EIAJ)

### Specifications

Part Number	Working Voltage		Varistor Voltage @ 1mA <sub>dc</sub>	Clamping Voltage	Capacitance pF	Peak Current (amps)	Transient Energy (Joules)
	V <sub>rms</sub>	V <sub>dc</sub>					
MLVA02V05C033	4	5.5	8-14	30	33	-	-
MLVA02V05C047	4	5.5	8-14	26	47	-	-
MLVA02V05C064	4	5.5	8-14	26	64	-	-
MLVA04V05C270	4	5.5	6.4-9.6	20	270	20	0.05
MLVA04V09C130	7	9	10-15	32	130	20	0.05
MLVA04V14C090	11	14	14.4-21.6	38	90	20	0.05
MLVA04V18C085	14	18	17.6-26.4	45	85	20	0.05
MLVA06V05C270	4	5.5	6.4-9.6	22	270	30	0.1
MLVA06V09C210	7	9	10-15	27	210	30	0.1
MLVA06V14C150	11	14	14.4-21.6	35	150	30	0.1
MLVA06V18C130	14	18	17.6-26.4	40	130	30	0.1
MLVA06V26C100	20	26	24.8-37.2	58	100	30	0.1

Working Voltage V<sub>rms</sub> - Maximum AC operating voltage the varistor can maintain and not exceed 10µA leakage current for 0402, 0603.  
 Working Voltage V<sub>dc</sub> - Maximum DC operating voltage the varistor can maintain and not exceed 10µA leakage current for 0402, 0603.  
 Varistor Voltage - Voltage across the device measured at 1mA DC current. Equivalent to V<sub>B</sub>, "breakdown voltage."  
 Clamping Voltage - Maximum peak current across the varistor with 8/20µs waveform and 1A pulse current.  
 Capacitance - Device capacitance measured with zero volt bias 1V<sub>rms</sub> at 1MHz.  
 Peak Current - Maximum peak current which may be applied with 8/20µs waveform without device failure.  
 Transient Energy - Maximum energy which may be dissipated with the 10/1000µs waveform without device failure.

Environmental Specifications	
Characteristic	Value
Bias Humidity:	+40°C, 90% RH for 1000 hours
Thermal Shock:	-40°C to +85°C, 30 minute cycle, 5 cycles
Operating Temperature Range:	-40°C to +85°C
Storage Temperature Range:	-40°C to +85°C
Full Load Voltage:	Working Voltage, 85°C, 1000 hours

**Soldering Recommendations**

- Compatible with lead and lead-free solder reflow processes
- Peak reflow temperatures and durations:
  - IR Reflow = 260°C max for 30 sec. max.
  - Wave Solder = 260°C max. for 10 sec. max.
- Recommended IR Reflow Profile:

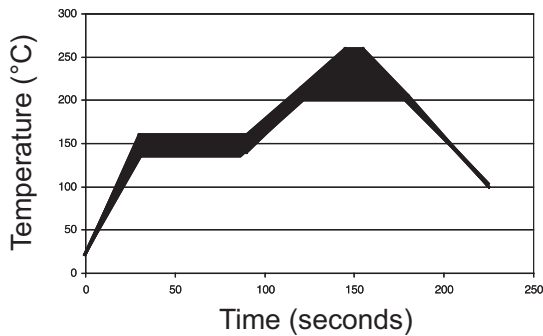

**Recommended Pad Layout - mm (in)**

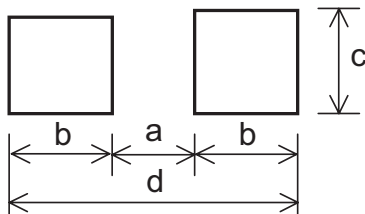

Size	a	b	c	d
0201	0.23 (0.009)	0.30 (0.012)	0.45 (0.018)	0.83 (0.033)
0402	0.51 (0.020)	0.61 (0.024)	0.51 (0.020)	1.70 (0.067)
0603	0.50 (0.020)	1.02 (0.040)	0.76 (0.030)	2.54 (0.100)

**Dimensions - mm**

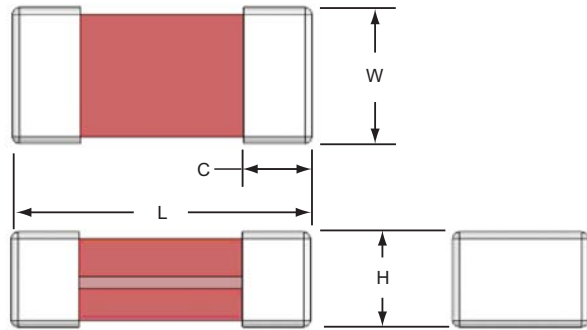

Size	L	W	H	C
0201	0.60±0.05	0.30±0.05	0.30±0.05	0.20±0.10
0402	1.00±0.15	0.50±0.10	0.50±0.10	0.25±0.15
0603	1.60±0.15	0.80±0.10	0.80±0.10	0.30±0.20

**Tape Packaging Specifications - mm**

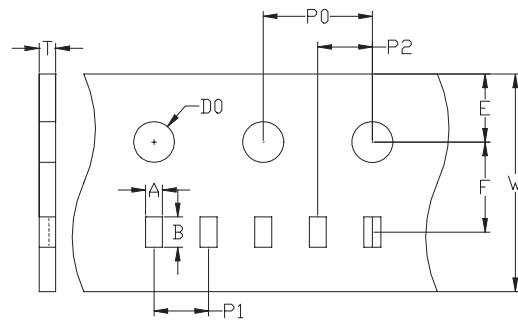

0201 Carrier Dimensions									
A	B	W	E	F	P0	P1	P2	D0	T
0.37 ±0.03	0.69 ±0.03	8.0 ±0.1	1.75 ±0.05	3.5 ±0.05	4.0 ±0.1	2.0 ±0.05	2.0 ±0.05	1.55 ±0.05	0.42 ±0.03
0402 Carrier Dimensions									
0.58 ±0.03	1.2 ±0.03	8.0 ±0.1	1.75 ±0.05	3.5 ±0.05	4.0 ±0.1	2.0 ±0.05	2.0 ±0.05	1.55 ±0.05	0.60 ±0.03
0603 Carrier Dimensions									
1.05 ±0.15	1.90 ±0.15	8.0 ±0.30	1.75 ±0.10	3.50 ±0.05	4.00 ±0.10	-	2.00 ±0.05	1.50 ±0.10	-

The only controlled copy of this Data Sheet is the electronic read-only version located on the Cooper Bussmann Network Drive. All other copies of this document are by definition uncontrolled. This bulletin is intended to clearly present comprehensive product data and provide technical information that will help the end user with design applications. Cooper Bussmann reserves the right, without notice, to change design or construction of any products and to discontinue or limit distribution of any products. Cooper Bussmann also reserves the right to change or update, without notice, any technical information contained in this bulletin. Once a product has been selected, it should be tested by the user in all possible applications.

Life Support Policy: Cooper Bussmann does not authorize the use of any of its products for use in life support devices or systems without the express written approval of an officer of the Company. Life support systems are devices which support or sustain life, and whose failure to perform, when properly used in accordance with instructions for use provided in the labeling, can be reasonably expected to result in significant injury to the user.